

# eva

creating an American tea ceremony



# inspiration

eva had one goal: to develop an heirloom product by creating a timeless object that is convivial, whimsical and creates a shared american tea ceremony.

The final design is influenced by three inspirations:

**Telling stories**

**The magic of childhood tea parties**

**The form and beauty of Eva Zeisel's nested vases**



## a simple approach

**eva** is a product designed around a conceptual model to re-think the responsibility of the designer and the role given to creating experiences and interactions for others. To design **eva**, a direct non-traditional design process was used, and research did not play an important role in its development. What was important was developing a reality around making tea and have a story emerge from the reality. The story becomes critical in determining a list of wants and needs, while also focusing curiosity based analysis and application of several key attributes.

Techniques deployed during the development of **eva** included:

Development of a design philosophy

Analysis of rituals and ceremonies

Analysis of how humans attach meaning to their objects

Development of forms and design language

Analysis and application of materials

Analysis and application of the guest-host relationship

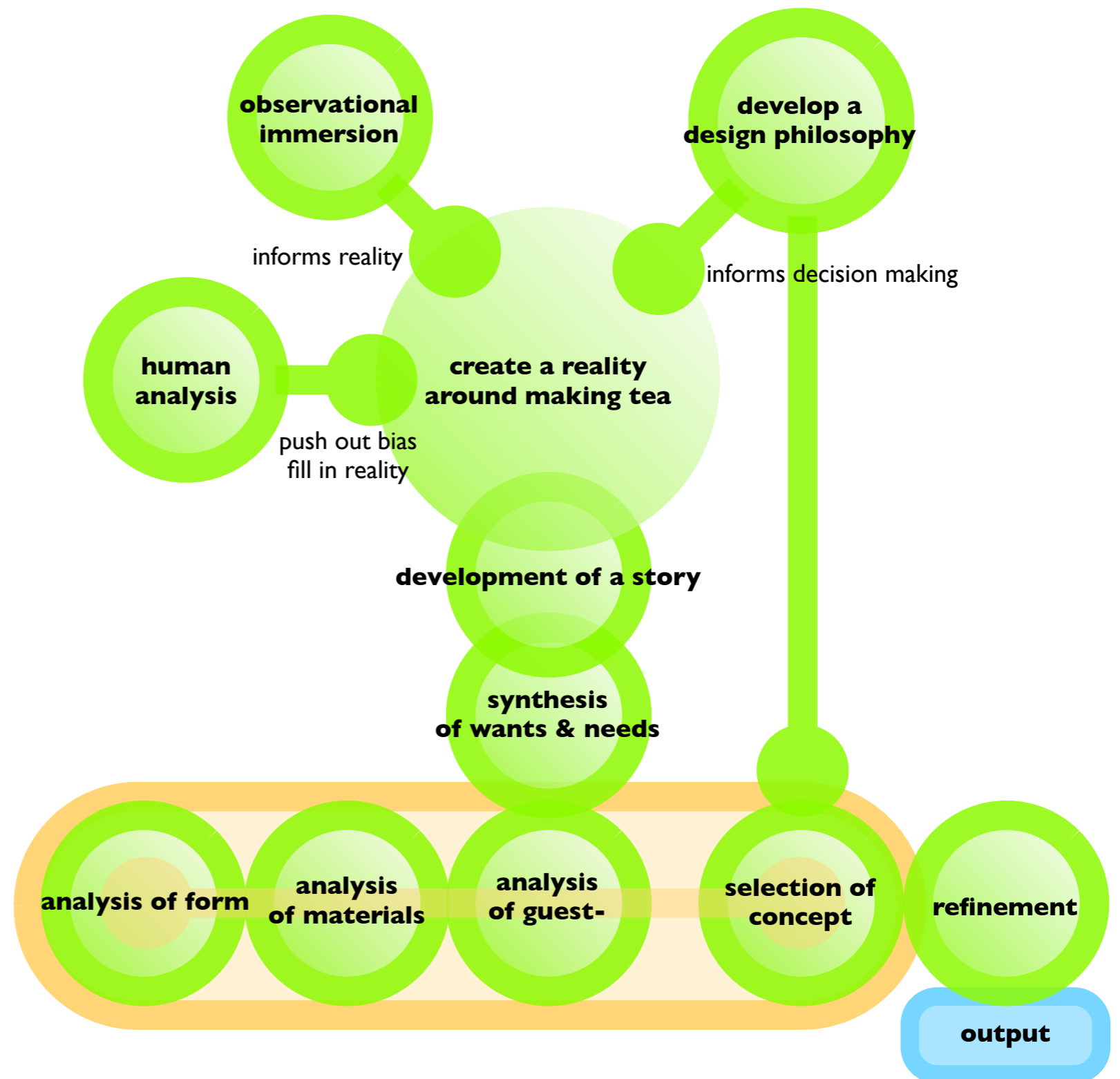

## A Reality

**eva** is about a mom who believes she has lost the meaningful connection with her daughter and longs to reconnect before her daughter moves out of the house for good. She starts to reminisce about her own childhood and becoming an adult. She thinks of the times when she shared meaningful moments with her own parents and wishes she had kept some of the artifacts that she loved growing up. A few days later, depressed, she finds herself searching Ebay for things she had lost from her past. Giving up, she thinks quietly, "memories are expensive". In her sadness she realizes she has no heirlooms to pass on to her daughter. Later in the hall the mom asks her daughter what her favorite childhood memory was. She thinks for a second and replies, "tea parties with my teddy bear Max." "You still have Max?" "Yes, and he still likes tea!" The mom smiles and whispers "self I think everything will be just fine"

No other scenario or persona were created. The philosophy being examined is: if the designer creates a specific scenario it limits and taints the interactions to be just for that scenario, and creates a contrived experience for every user; thus not allowing the individual to create and attach their own more meaningful experience to the object. This approach allows for forming a bond and emotional attachment that can lead to becoming an heirloom. In **eva's** case, an open-ended story was used to let the designer imagine an object that the characters in the story would find desirable and meaningful to their lives.



## design intent

eva's design intent is to facilitate a savoring of small moments for two to four people. Its domain involves people coming together to be part of the pure enjoyment of socializing, telling stories, gossiping or reminiscing over a cup of tea. Eva is not about technology or innovation. It is about being in an authentic experience and not allowing the object becoming the experience. Its role is to make the guest feel welcome and special, to provide a gift to the participants, and then move to background. eva is informed by Ray and Charles Eames' concept of the guest-host relationship. It is an object that is intended to be slow and process based.



## design language

eva's design language follows two main themes:

Form abstraction of a tea set

Forms and textures that enhance and inform the participants of the guest-host relationship.

### **Abstractions:**

The handle is an abstracted tea cup.

The tea pods sit in a saucer metaphor

The base is an abstraction of a doily

### **Form:**

All community components are in support of the individuals such as the water vessel and the base are symmetrical.

All pieces that participants touch and use are asymmetric to reflect the guest and hosts individuality.

### **Surfaces and textures:**

The water vessel is pitted polished aluminum, it is polished to reflect the participants in the communal pot.

The surface is pitted to give interest and contrast to the pieces that are handled. It is also to educate and create a new aesthetic for non-virgin materials.

Surfaces that are touched and handled (except for the glass) have a satin finish. The effect created is velvety warm to touch and intended to minimize the effect of fingerprints.

### **Temperature:**

The glass is double lined and air insulated so not to be hot to the touch, all surfaces are intended to transfer warmth to the participants

Wood is used to connote the warm, sharing and good nature of the host.



# the ceremony

eva creates a simple but convivial american tea ceremony with several symbolic metaphors that harken back to basic humanist rituals and time honored ceremonies such as:

the pouring of water

gathering around a fire

the gift and offering of the water in to each pod

the magic filling of each pod

the dance of the tea

sharing warmth

release and control

the receiving and accepting of a gift



## the process

**eva** creates a simple but convivial American tea ceremony. It suggests a process or a ceremony but it does not force a ceremony. It is open to the host to develop his or her own personal use ritual. One such ritual may happen as suggested below:

the three guests gather at the table

the host removes **eva** from the charging plate and brings **eva** to the table

the guests are invited to take a pod and select a tea

guests have the option of selecting bags or loose tea

each guest puts the tea in his or her own pod and returns the pod to the base

the host invites a guest to pull up the plunger mechanism until it stops

the host pours fresh clean water in to the vessel

the host pushes down on the lid to initiate the heating sequence

the guest and host relax and start enjoying the event

several minutes later, **eva** starts to sing a pleasant tone signaling a low tea temperature is ready  $\sim 145^{\circ}\text{F}$

a few moments later a second tone is added for a medium temperature has been reached  $\sim 180^{\circ}\text{F}$

finally a few moments later, if needed, a third soft tone is added to the chorus signaling that **eva** has reached its maximum temperature  $\sim 195^{\circ}\text{F}$

when the desired temperature is reached the host pushes down on the plunger

the guest delights as the water magically appears in each pod

the loose tea and tea bags dance with delight as the water swirls in the pod

the guest is free to let the tea steep as long as they wish

the pods are kept warm with a warmer plate under each pod

the guests share the warmth of the pod as they reach for and take them off the base

they fill their cups, replace the pods, and savor the moment

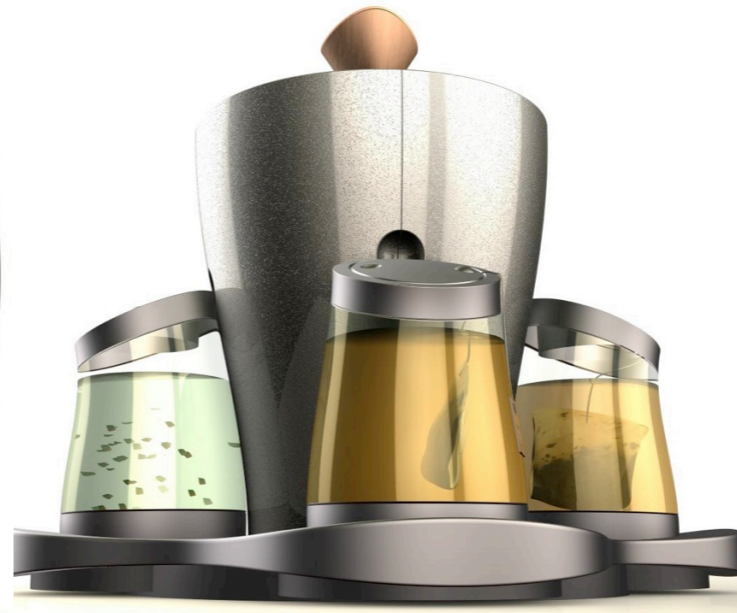

when water reaches desired temperature  
the host or guest presses into the pods

## attributes

**eva** has several key design features to enhance the interaction with and to aid in eva's intuitive use. creating pleasure and joy.

sensor and pod lock  
ceramic pod warmer  
uni-directional fill diaphragm. with auto flow stop if no pod or pod is removed

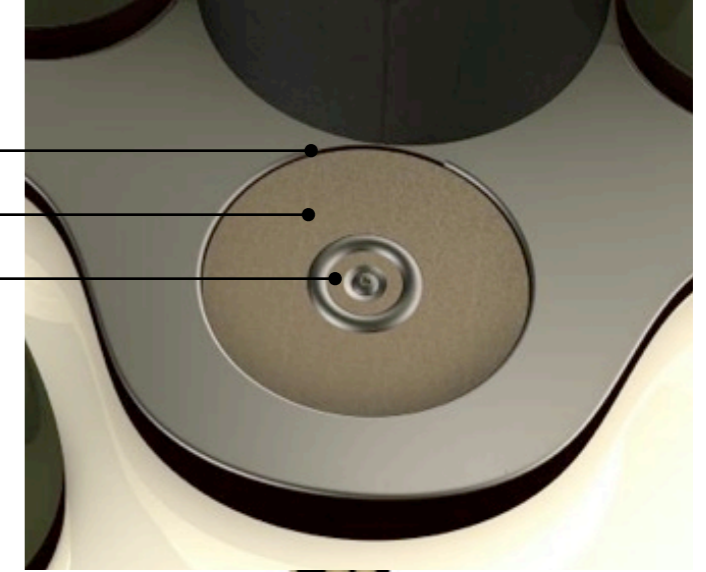

three tone temperature whistles built into shaft, use steam pressure

gold filters keep water clean and tasting fresh

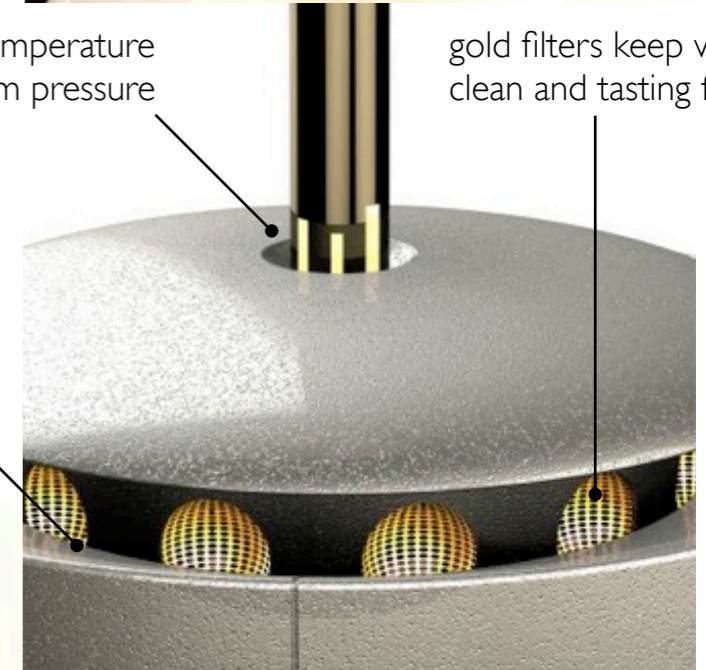

lid opens to receive water

flip lid accepts loose or bagged tea



lid closes air tight to initiate heating

pod pour spout is welcomed and received by communal pot

dimples and nipples indicate open and close

the tea dances as hot water fill from the bottom of the pod

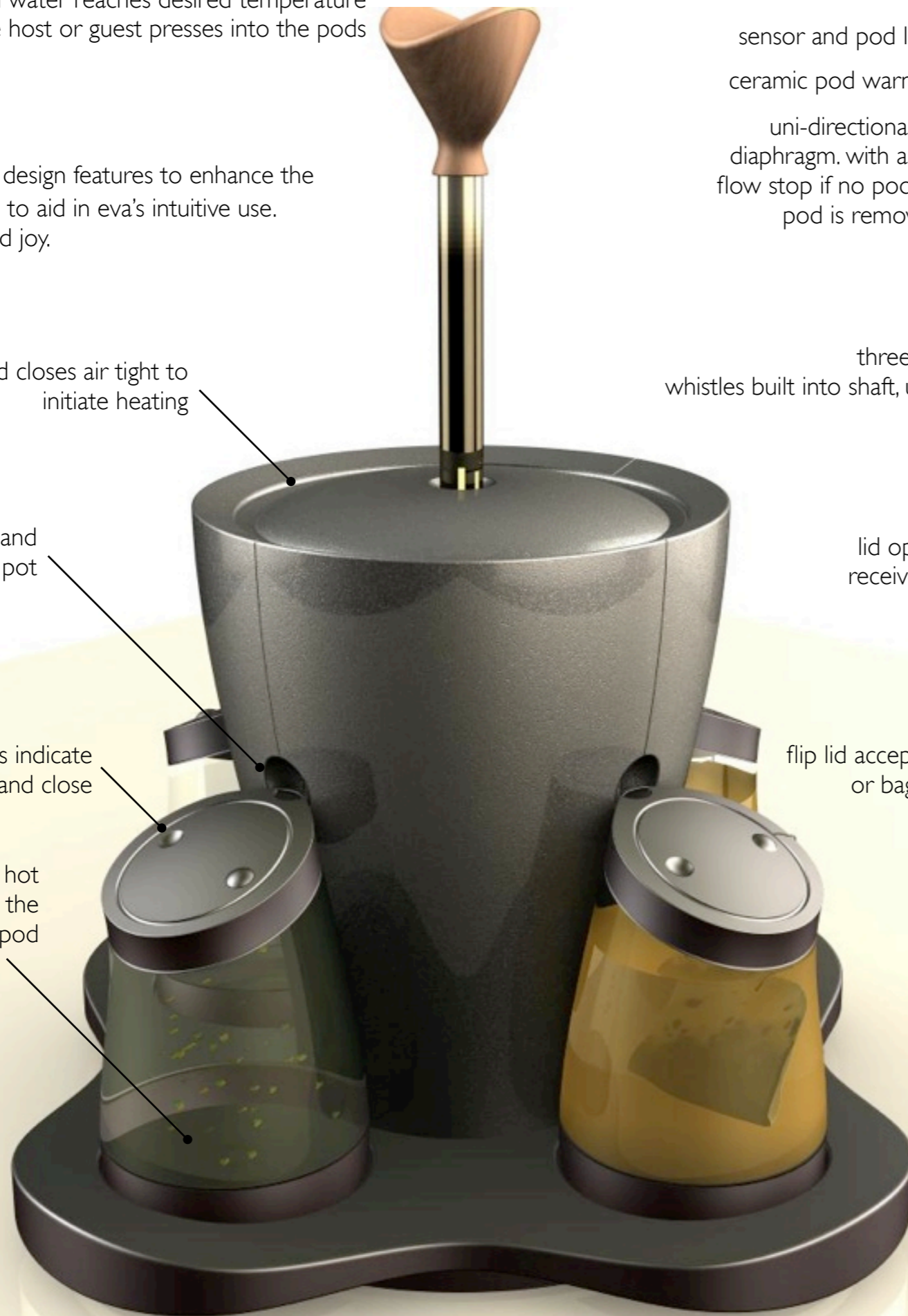

## American materials

**eva** is designed using historically and psychologically American materials, Aluminum, Glass and Maple have each played and continue to have an influential role in our in our dally lives as Americans. They are not unique to us but they are distinctly American materials.



**reclaimed aluminum**  
multiple sources



**reclaimed glass**  
clear milk & coke bottles

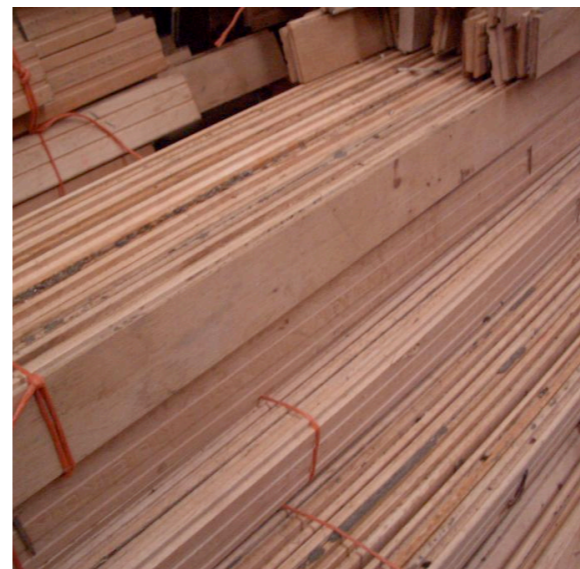

**reclaimed maple**  
gym & factory floors

+



**aluminum water bottles**  
polymer or ceramic bonded  
blocks metal taste

## manufacture

eva's goal is to use excess American manufacturing capacity to create very simple, durable and beautifully crafted parts that are easy to assemble. With few wear parts and no pumps or motors, eva is designed to last several lifetimes.

eva's only replacement part is the rechargeable battery and the Teflon and rubber gaskets.

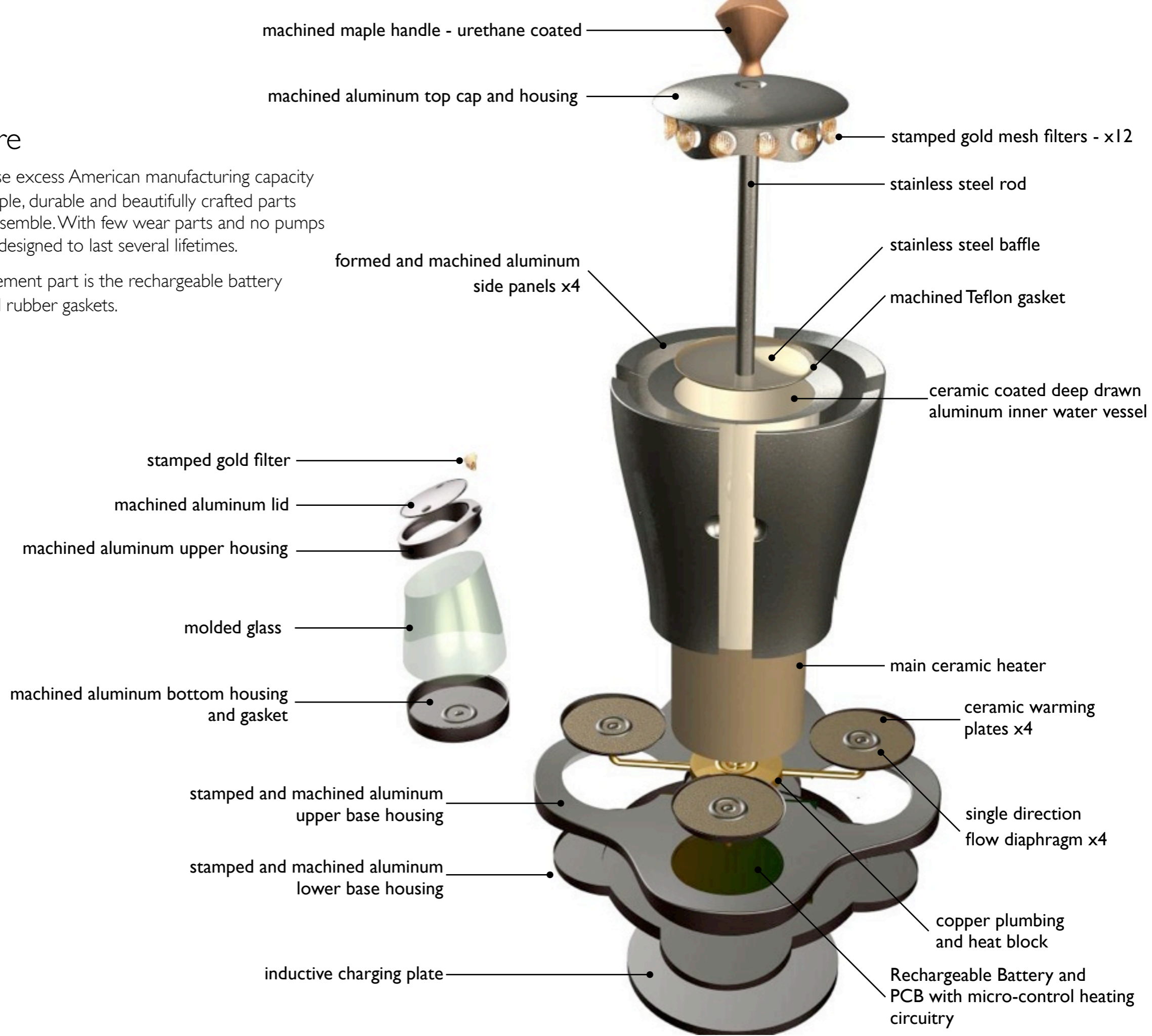

# Heirloom

**eva is not designed to be to a massed produced item.**

A reasonable production would be 5,000 -10,000 units over the life the product, or approximately 1.000 units a year. Its materials and manufacturing processes follow green and sustainable trends and can and should be produced in the USA to lower total carbon footprint. Using recycled materials and simple manufacturing processes that use less waste material, coupled with new processes for lining the aluminum with a ceramic polymer; allows the use of a material (aluminum) that historically could not be considered a proper material for the enjoyment of tea.

With developing the philosophy of designing an heirloom with reasonable market growth expectations products like **eva** can achieve the ultimate sustainability by not becoming part of the archaeological record and not adding a backside carbon foot print with recycling.



## size

eva is larger than and uses more material than a conventional tea pot. With the weight saving of aluminum and ruggedness of the materials chosen, the overall packing and transportation burden should not be significantly greater than a comparable high end tea pot.

With the goal of developing an heirloom, the designer hopes to mitigate ecological burden and total carbon footprint by offsetting material and transportation with the fact that fewer objects are being disposed of.

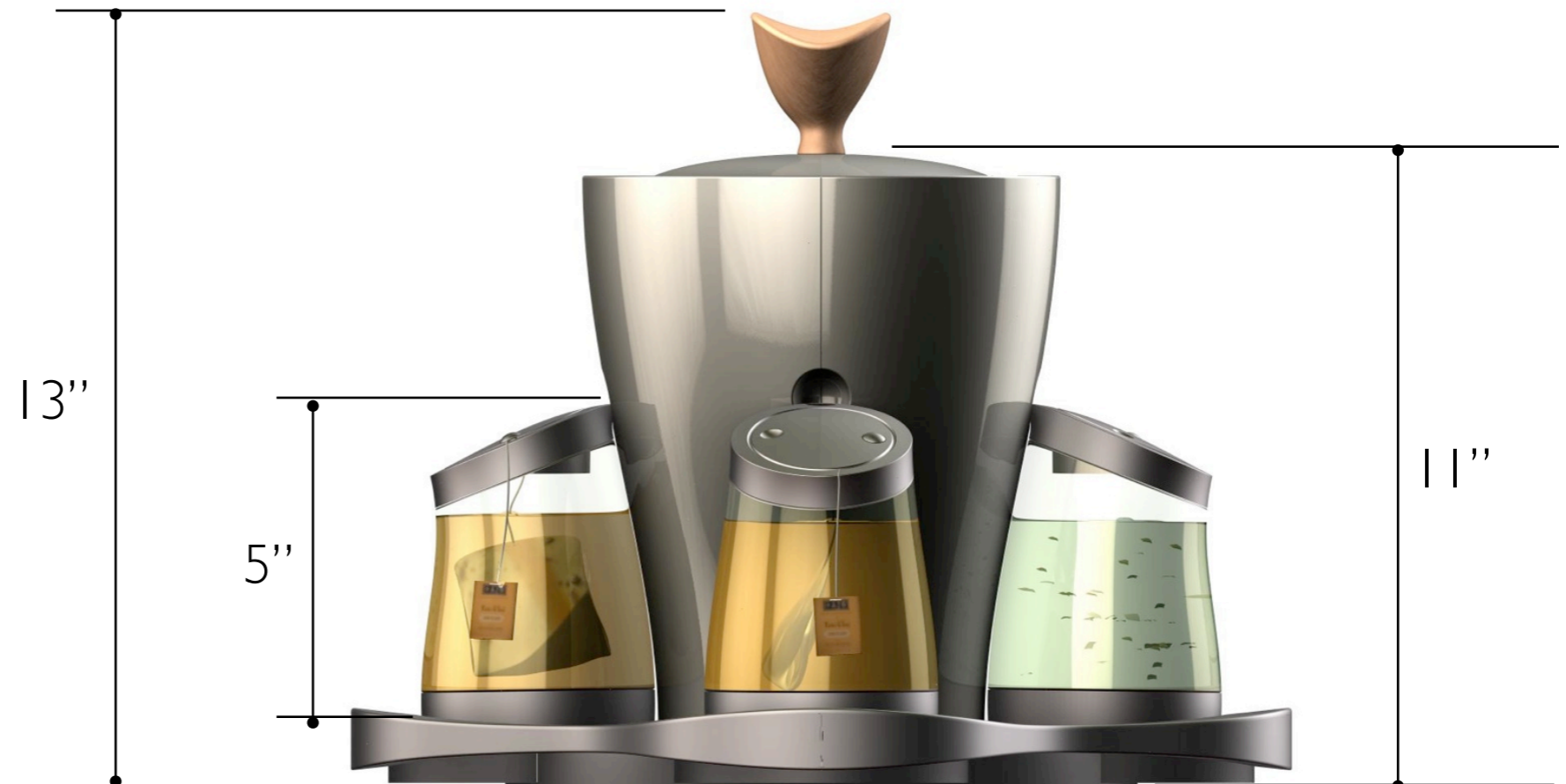
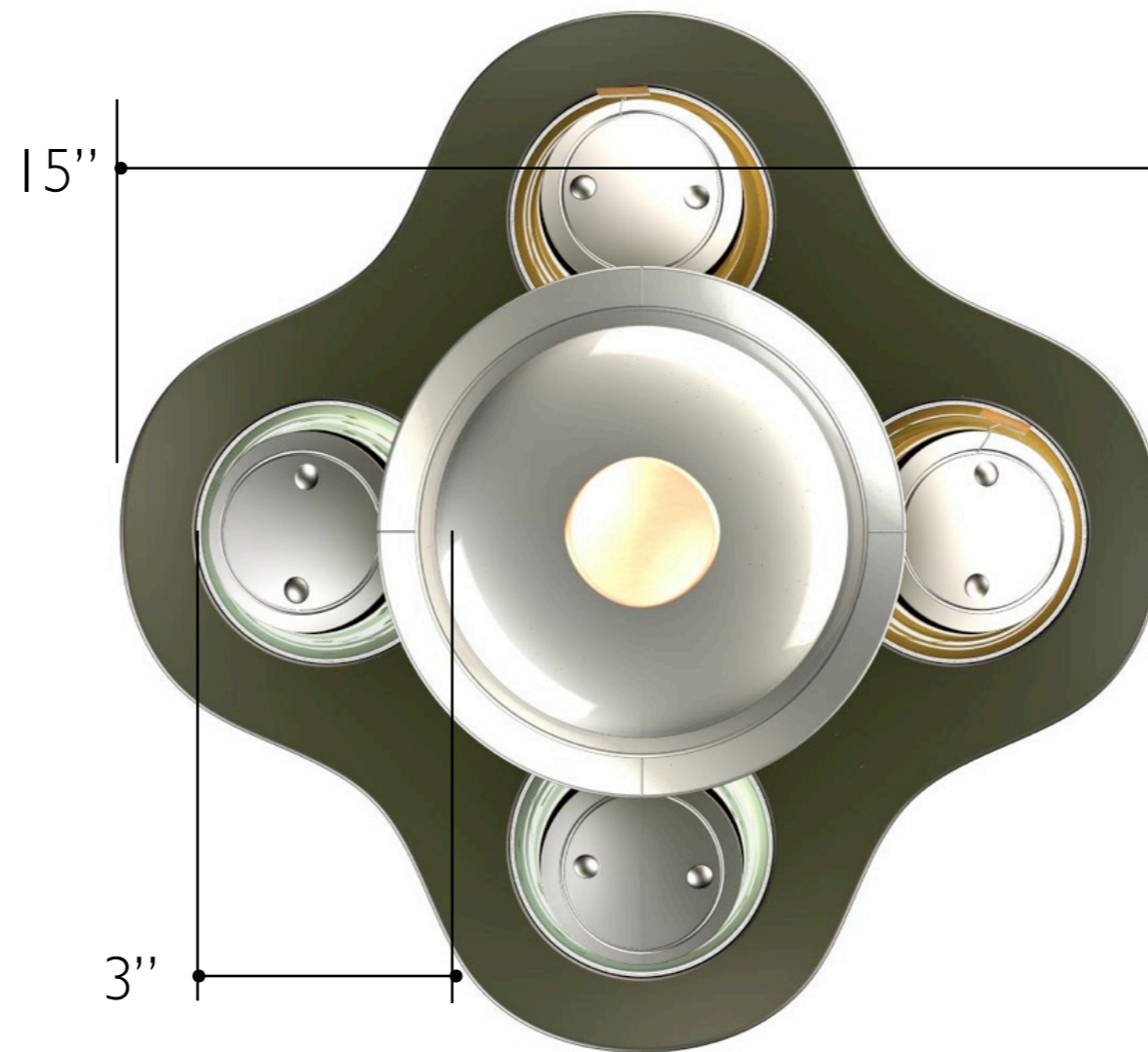

thank you  
enjoy

